



## ⚠ WARNING

To prevent **SERIOUS INJURY, DEATH or PROPERTY DAMAGE:**

- **ALWAYS** read, understand and follow warnings and instructions for your hitch **BEFORE** installation. Keep for future reference.
- **DO NOT** cut, weld or modify this receiver.
- **CHECK** all fasteners are tight and your hitch is securely mounted to your vehicle periodically.
- **ALWAYS** read, understand and follow all warnings and instructions for your vehicle and for other accessories you will use with your hitch **BEFORE** use.
- **LOAD** the trailer heavier in front.
- **DO NOT** exceed lower of towing vehicle manufacturer’s rating or:

Hitch Type	Max Gross Trailer Weight	Max Tongue Weight
Weight Carrying	6000 lb. (2724 kg)	900 lb. (409 kg)
Weight Distributing	N/A	N/A

- **ALWAYS** wear your seatbelt.
- **SLOW DOWN** when towing, **NEVER** exceed any posted speed limit.
- If **EXCESS SWAY** occurs, take your foot off the gas pedal and hold the steering wheel as steady as possible. **DO NOT** apply your brakes and **DO NOT** speed up.

## LIMITED LIFETIME WARRANTY

1. **Limited Lifetime Warranty (“Warranty”).** Cequent Performance Products, Inc. (“We”, “Us” or “Our”) warrants to the original consumer purchaser only (“You” or “Your”) that the product will be free from material defects in both material and workmanship, ordinary wear and tear excepted. The Warranty is valid only if (a) the products are returned to Us for inspection and testing; (b) Our inspection discloses to Our satisfaction that any alleged nonconformance are material and have not been caused by misuse, neglect, wear and tear, improper installation, unsuitable storage, improper repair, alteration, or accident; and (c) the products were installed, maintained and used in accordance with Our instructions. **THE WARRANTY IS MADE IN LIEU OF ALL OTHER WARRANTIES, EXPRESS OR IMPLIED (OTHER THAN THE WARRANTY OF TITLE AS PROVIDED BY THE UNIFORM COMMERCIAL CODE IN EFFECT IN MICHIGAN), INCLUDING WITHOUT LIMITATION, ANY WARRANTIES OF MERCHANTABILITY OR FITNESS FOR A PARTICULAR PURPOSE, SAID WARRANTIES BEING EXPRESSLY DISCLAIMED.**
2. **Obligations of Purchaser.** To make a Warranty claim, contact Us, identify the product by model number, and follow the claim instructions that will be provided. Any returned product that is replaced by Us becomes our property. You may be responsible for return shipping costs. Please retain your purchase receipt to verify date of purchase and that You are the original consumer purchaser. The product and the purchase receipt must be provided to Us in order to process Your Warranty claim.
3. **Exclusive Remedy.** Product replacement is Your sole and exclusive remedy under this Warranty. We shall not be liable for service or labor charges incurred in removing or replacing a product. **IN NO EVENT WILL WE BE RESPONSIBLE FOR ANY INDIRECT, SPECIAL, CONSEQUENTIAL OR PUNITIVE DAMAGES.**
4. **Assumption of Risk.** You acknowledge and agree that any use of the product for any purpose other than the specified use(s) stated in the product instructions is at Your own risk.
5. **Governing Law.** This Warranty gives You specific legal rights, and You also may have other rights which vary from state to state. This Warranty is governed by the laws of the State of Michigan, without regard to rules pertaining to conflicts of law. The state courts located in Oakland County, Michigan shall have exclusive jurisdiction for any disputes relating to this Warranty.



## Applications:

Years	Make	Models
2017-Current*	Jaguar	F-Pace

\*Visit our website for the most up to date information regarding application years and trim levels.

## Installation Time: 90 min

The time listed above is the average time for professional installers. If you do not feel comfortable performing this installation on your own or are in need of assistance, please contact a professional installer.



Representative Vehicle Photo

## Equipment Required:

Safety Glasses	Ratchet	8 mm 10 mm 21 mm Sockets	6" Socket Extension	Torque Wrench	T20 Torxbit Socket
Silicone Sealant	Plastic Trim Tools	Utility Knife	Tape	Phillips Screwdriver	

## DO NOT EXCEED LOWER OF TOWING VEHICLE MANUFACTURER'S RATING OR:

Hitch Type	Max Gross Trailer Weight	Max Tongue Weight
Weight Carrying	6000 lb. (2724 kg)	900 lb. (409 kg)
Weight Distributing	N/A	N/A

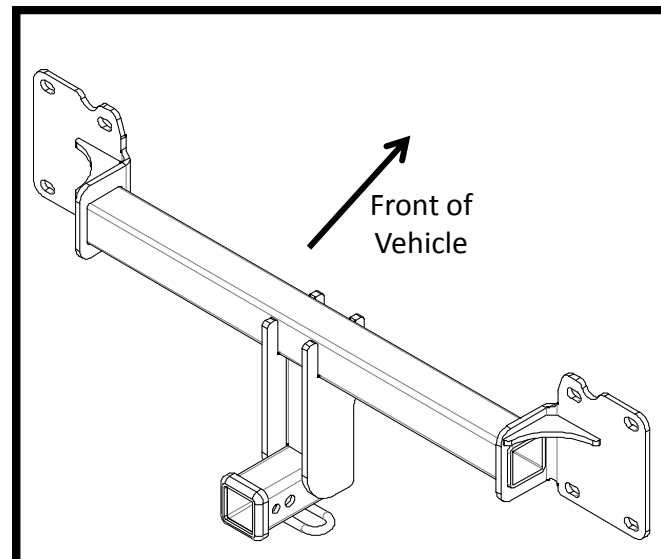

Hitch Illustration

**Always wear SAFETY GLASSES when installing hitch**

# Installation Instructions

PART NUMBERS: 76026, 84026, CQT76026

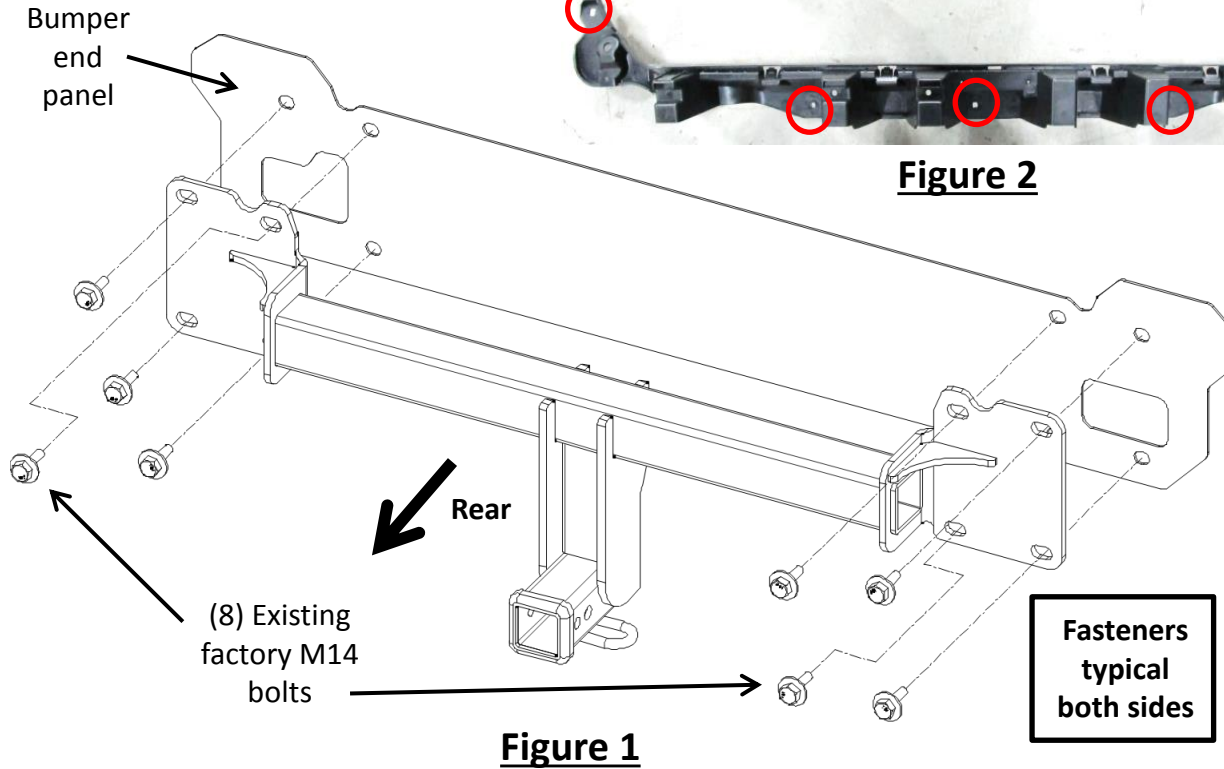

**Figure 2**

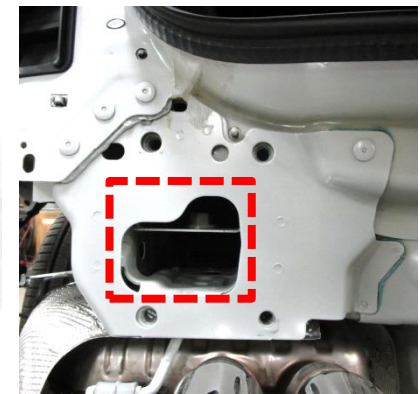

**Figure 3**

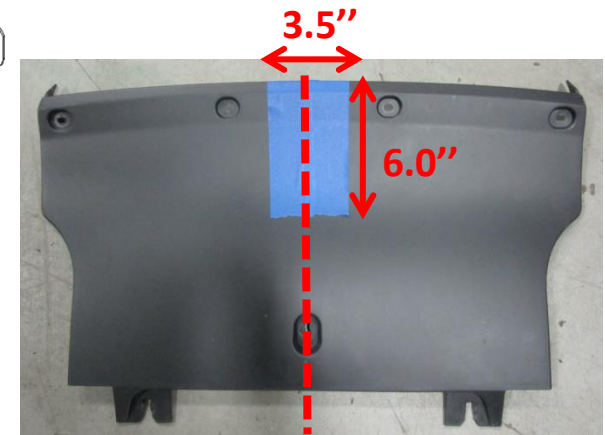

**Figure 4**

- 1. Bottom appearance panel removal** – Use 10 mm socket to remove (3) screws and screwdriver to remove (4) plastic screws from the bottom panel. Carefully remove the bottom panel and set it aside for reinstallation.
- 2. Fascia removal** – (a) Open the rear hatch. Remove interior trim panel next to taillight each side. Use 10 mm socket to remove (1) screw behind interior trim panel each side. Use screwdriver to remove (1) plastic screw from the fascia each side. (b) Use screwdriver to remove (2) screws from wheel well each side. Behind the wheel well, use T20 torxbit socket to remove (2) screws and screwdriver to remove (4) screws each side. (c) Use plastic trim tools to remove the fascia starting at the outer edges near the wheel wells and gently pull the fascia. Disconnect wiring harness on driver side if present.
- 3. Bumper beam removal** - Use 8 mm socket to remove (5) screws from the panel above bumper beam, see **Figure 2**. Use 21 mm socket to remove (4) M14 factory bolts from bumper beam each side. Gently remove the panel and bumper beam and set them aside. Return bumper beam to vehicle owner.
- 4. Hitch installation** - Use silicone sealant to seal around the opening on the end panel each side, see **Figure 3**. Raise the hitch into position and align it with bumper end panel holes. Loosely secure the hitch to the bumper end panel using (8) existing M14 factory bolts removed in Step 3, see **Figure 1**.
- 5. Tighten all M14 fasteners with torque wrench to 115 Lb.-Ft. (156 N\*M).**
- 6. Bottom appearance panel trimming** – locate the center of bottom panel and trim 6.0" tall by 3.5" wide area, see **Figure 4**.
- 7. Reinstall all fasteners, bumper panel, interior trim panel, wiring harness, fascia, and appearance bottom panel removed in Step 1, 2, 3.**

**Proper torque is needed to keep the hitch secure to the vehicle when towing.**

Note: check hitch frequently, making sure all fasteners and ball are properly tightened. If hitch is removed, plug all holes in trunk pan or other body panels to prevent entry of water and exhaust fumes. A hitch or ball which has been damaged should be removed and replaced. Observe safety precautions when working beneath a vehicle and wear eye protection. Do not cut access or attachment holes with a torch. This product complies with safety specifications and requirements for connecting devices and towing systems of the state of New York, V.E.S.C. Regulation V-5 and SAE J684.

**1. Bottom appearance panel removal** – Use 10 mm socket to remove (3) screws and screwdriver to remove (4) plastic screws from the bottom panel. Carefully remove the bottom panel and set it aside for reinstallation.

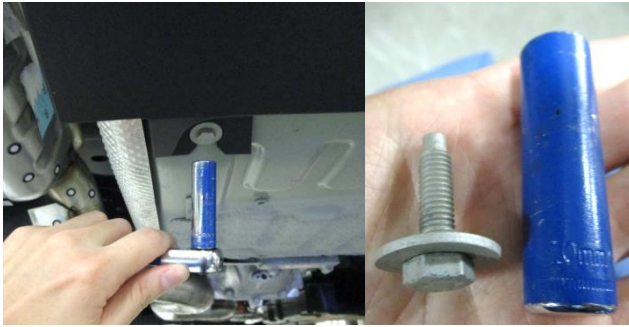

**2. Fascia removal** – (a) Open the trunk. Remove plastic cover piece next to taillight each side. Use 10 mm socket to remove (1) screw behind plastic cover piece each side. Use screwdriver to remove (1) plastic screw from the fascia each side.



**2. Fascia removal – (b)** Use screwdriver to remove (2) screws from wheel well each side. Behind the wheel well, use T20 torxbit socket to remove (2) screws and screwdriver to remove (4) screws each side. **(c)** Use plastic trim tools to remove the fascia starting at the outer edges near the wheel wells and gently pull the fascia. Disconnect wiring harness on driver side if present.

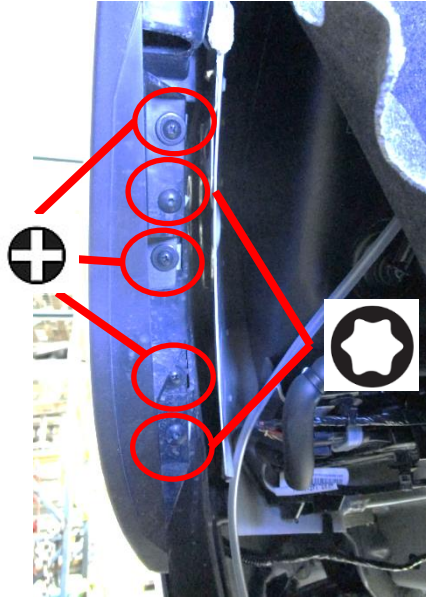
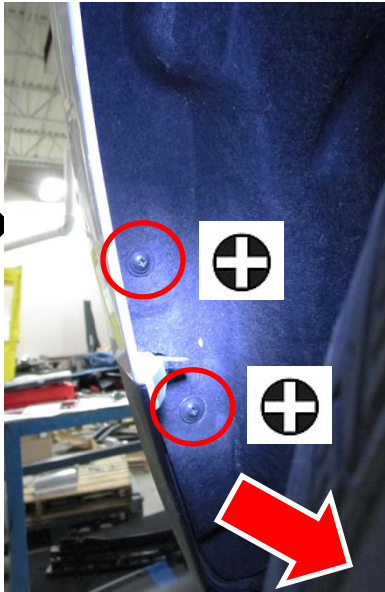

**3. Bumper beam removal -** Use 8 mm socket to remove (5) screws from the panel above bumper beam, see [Figure 2](#). Use 21 mm socket to remove (4) M14 factory bolts from bumper beam each side. Gently remove the panel and bumper beam and set them aside. Return bumper beam to vehicle owner.



**4. Hitch installation** - Use silicone sealant to seal around the opening on the end panel each side, see **Figure 3**. Raise the hitch into position and align it with bumper end panel holes. Loosely secure the hitch to the bumper end panel using (8) existing M14 factory bolts removed in Step 3, see **Figure 1**.

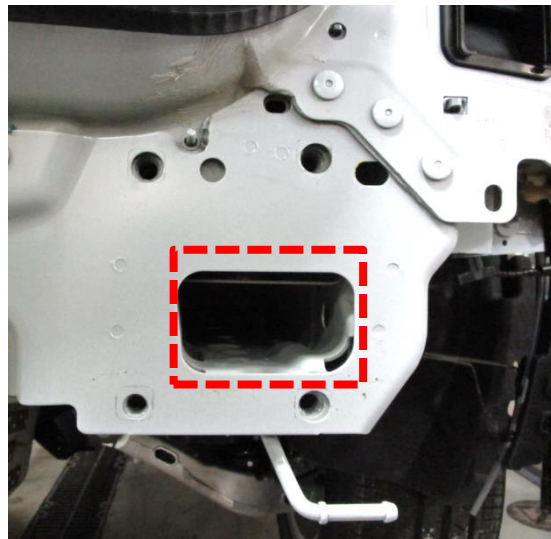
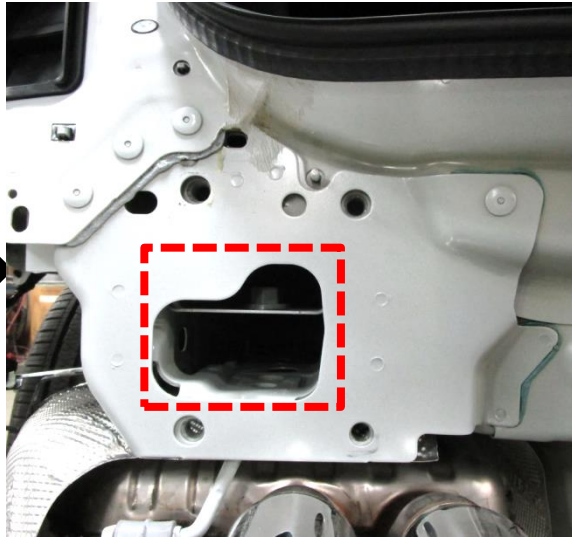

**5. Tighten all M14 fasteners with torque wrench to 115 Lb.-Ft. (156 N\*M).**

**6. Bottom appearance panel trimming** – locate the center of bottom panel and trim 6.0" tall by 3.5" wide area, see **Figure 4**.

**7. Reinstall all fasteners, bumper panel, plastic cover piece, fascia, and appearance bottom panel removed in Step 1, 2, 3.**

**⚠ Proper torque is needed to keep the hitch secure to the vehicle when towing.**

